

# THE GLASS ROOF: SLOPED GLAZING NEED NOT LEAK

Chris B. Makepeace

John O'Connor  
Member ASHRAE

---

## ABSTRACT

*The observations presented in this paper are based on the investigation of more than 100 leaking sloped aluminum and glass roof installations. The principles presented have been developed through discussions with testing agencies, researchers, designers, aluminum framing manufacturers, installers, maintenance personnel, and other building science specialists for the past 20 years.*

*For the purposes of this paper, the details are conceptual so as not to represent any particular manufacturer's system, although some similarities may be discernible. The description of the details and the performance observations are based on actual installations of several manufactured aluminum profiles that have been modified to follow the principles described in this paper. These installations have provided a sloped glass roof that does not leak.*

*There is no such thing as a standard design for a sloped, glazed roofing system of more than one lite. Each design becomes a custom system to some degree, depending on the*

*manufacturer's aluminum framework profiles and the design loads that must be accommodated. The basic materials of aluminum and glazing units do not leak. The leaks occur where these components join each other or where the system joins the building envelope system of the remainder of the building.*

*Designs that are based on sole reliance of the exterior seals to provide a single line of defense to water entry have repeatedly proved to be a flawed approach. Designs where the watertightness seals are placed in a protected location, with minimal contact with water and where water is controlled and redirected to the exterior through the design of the framing, have provided watertight installations. This alternative concept may sound simple, but the details of how this can be accomplished are complicated by the limitations and compromises imposed by the design and by available systems. If the owner is willing to pay for a waterproof glass roof, the others in the team can construct it.*

---

## INTRODUCTION

At least one of the magazines produced each month for the architectural, engineering, building owners, building operators, or real estate communities will have an article on the variety of benefits of the use of glass in the building envelope. Sloped glazing often is a major part of such articles. Skylights and atriums with sloped glazing are expressed as the great design tools used by architects to give building exteriors a signature and presence, while within the interiors of buildings they provide an exterior view orientation, comfort, and warmth. Also, they enhance the occupant's perception of the interior space. The positive effects on productivity, stress, and wellness of humans as a result of natural light has been well documented. The problems resulting from marginal design by some architects and manufacturers, the poor attention to details by them and the installers, and the incorrect maintenance by building operators rarely are mentioned in detail in such publications. Yes, sloped glazing can be of great benefit to the architectural design, but it can be a building owner's worst nightmare.

Sloped glazing is a roof, a glass roof, and, like any other roof, people expect it not to leak. Unfortunately, that is not always the case. When it leaks, it can speed up the degradation of the components that make up the sloped glazing system, increasing the leakage problem and/or requiring replacement of failed components within the system. Water leaking through sloped glazing systems can degrade the construction at its perimeter, resulting in roof damage; corrosion of steel elements within the roof, ceilings, and walls; and stain and/or break down drywall, interior finishes, and carpet. Water leaking through sloped glazing can follow structural elements to finally appear in remote parts of the building. When sloped glass roofs leak onto floors or stairs, they not only damage carpet and stain tiles but the leakage can turn into a serious safety hazard for the public.

In one public mall in Edmonton, the maintenance staff placed 200 buckets to collect water leaking through an aluminum and plastic system. The cost to repair the system was more than the original cost, so the owners held off on replacement until one day when a panel broke and fell, narrowly missing a pedestrian. Had the

---

Chris B. Makepeace and John O'Connor work in the Building Envelope Branch, Technical Resources Division, Alberta Public Works, Edmonton, AB, Canada.

panel hit her and resulted in any injury, the litigation and its cost could have been well beyond the cost of replacement.

## DESIGN PRINCIPLES

Little information is available to architects in the way of design information. Most architects rely on the manufacturers to provide the details for their particular system. Manufacturers develop their design in response to the demands of the marketplace and slant toward their particular component that makes up the system. The aluminum manufacturers produce designs that deal with the advantages of aluminum, but sometimes fall short when it comes to considerations of the glass or seals. Panelized glazing and acrylic manufacturers often neglect the effect of the frame on performance. There is a great difference of opinion on how to accomplish all the details necessary for a well-functioning system. Compromises within all designs created by the industry may jeopardize the overall performance, both short and long term. The design must adequately address the basic principles of sloped glazing systems.

There are mainly two approaches taken by manufacturers. The first and most prevalent is to rely on the exterior seals between the components to keep water from entering into the glazing framing. These systems may provide some sort of interior seal, especially between the frame and glazing. However, no real emphasis is placed on providing a water seal at these interior junctions of components.

The problems with such an approach include exposure of the exterior seal and/or sealants to ultraviolet radiation, thermal stresses, reaction to pollutants, and workmanship. Installers must clean, prime, place, and tool sealants in various weather conditions with the hopeful result of providing a 100% perfect, long-lasting finished product. Millions of dollars are spent every year in recaulking the exteriors of buildings that rely on this approach. All too often when a sloped glazing system leaks, the maintenance staff calls for the next layer of sealant on all the joints.

The second approach is based on realizing that the exterior seals will not be completely watertight. The watertight seals are designed on the interior of the system to minimize their contact with water and to drain what water is in the system back to the exterior. Some manufacturers have realized the folly of the first approach and have started to make changes over the last years to change their designs. It has been difficult in today's marketplace, however, to make a watertight system and still remain competitive.

Modern vertical aluminum and glass systems used in high-rise construction are based on this second approach (Figure 1). Using pressure equalization and draining of the glazing rabbet in what is commonly referred to as a rain screen design (Garden 1963; Brown

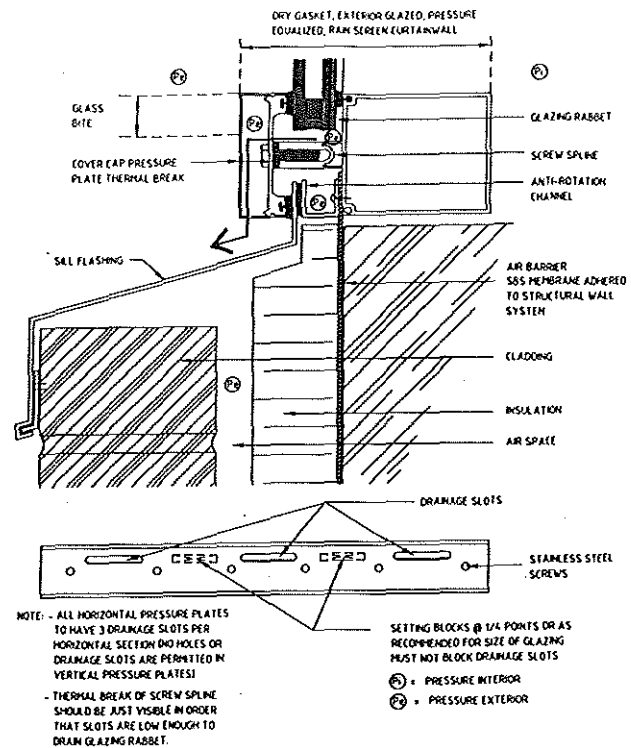

Figure 1 Exterior glazed curtainwall pressure equalized rainscreen.

et al. 1991). Air pressure differences across the exterior surface of a wetted wall can drive water through the imperfections present in the exterior seals. Equalizing the pressure across the cladding components and exterior seals that act as a screen to the inner wall can eliminate these forces, hence the name pressure-equalized rain screen. To accomplish this equalization of pressure, the presence of other features is necessary in the framing system: an effective air barrier, a compartmentalized glazing rabbet, and a large protected venting area through the cladding relative to the leakage area of the air barrier.

The air barrier is created by the inner lite of glass of the unit, the seal between this inner lite of glass and the frame, the frame tube face of the glazing rabbet, and the sealed joints of the framing sections. Compartmentalization is achieved by a continuation of this barrier out through the screw spline, thermal break, and pressure plate to form a pocket of air between the sealed unit edge and frame. This pocket is called the glazing rabbet.

Compartmentalization is not complete unless the small gap at the corners created by the lack of an extension of the screw spline is filled with a corner plug. Venting is provided through slots in the pressure plate, which also can act as drains should any water enter the glazing rabbet.

Interior seals between aluminum and glass of butyl tapes, sealants, plugs, and gaskets are protected on the

interior of such a design from water, so their performance is not affected by water.

Failure of vertical glazed walls, used in sloped glazing applications, is frequent because the water is not drained through the exterior face of pressure plates and cover caps but is held at a variety of interior butt joints of the systems, where it either finds a hole or degrades the sealant materials until a hole is created. Leaving out the corner plugs in an effort to drain water down the verticals eliminates compartmentalization of individual units, thus reducing the effectiveness of the pressure-equalized design. Additional water entry floods the glazing rabbet, while pumping of the system during windy conditions can drive water through the interior seals that are now exposed to water. Sealants used in joints between frame sections or between frame and glass prematurely break down. Sealed units positioned in a nondraining glazing rabbet will lose their seals prematurely, resulting in fogging of the unit.

The components and methods used to install both vertical and sloped glazing systems have a great deal in common, but differences in the design to control the water that bypasses the exterior deterrent seal sets them apart. How the water is drained back to the exterior will determine the performance of the systems and set the two systems apart.

As the designs of buildings and the construction of those designs are different, so are the designs and construction of each sloped glazing installation. Some simple concepts, however, if followed, can be the difference between success and failure.

1. Maximize the effectiveness of the outside sealant or gasket system, but do not rely on it to provide total waterproofing for the system.
2. Minimize or eliminate the ponding of water at these exterior seal locations. This will prolong the effectiveness of the seal and reduce the buildup of dirt and other contaminants that may be allowed to enter the system if an imperfection exists. Water ponding at the exterior seals can be pumped into the system through imperfections by the movement of glazing materials under high wind conditions.
3. When water does get into the glazing rabbet it must be contained, controlled, and redirected back to the exterior. The glazing rabbet provides a gutter that should provide adequate separation between water and the interior seals of the system (Figure 2). The gutter is created by the screw spline, tube face, and glazing leg of the rabbet. The glazing leg is elevated to ensure that the glazing does not sit in water, where its components and seals can be degraded by water.
4. Pressure equalization of the glazing rabbet will not perform to the same extent as it does in a vertical wall system due in part to the lack of compartmentalization of the interconnected glazing rabbets of the indi-

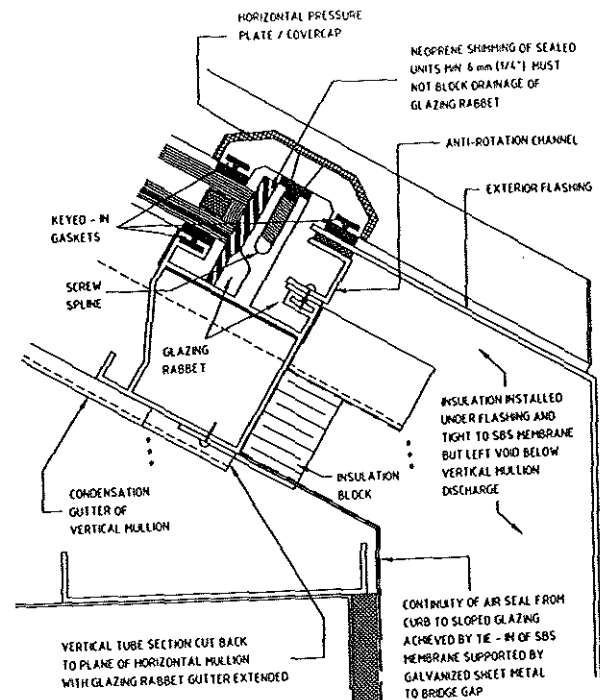

Figure 2 Horizontal mullion-section sill.

vidual glazings. It is still extremely important, however, to provide an effective "air barrier" plane within the system. Without this separation between the inner and outer environments, the building envelope is incomplete and can provide a pathway for both air and water to be transported through the envelope (Handegord 1979; Quirouette 1982, 1985; Wilson 1961; Dalgliesh and Schriever 1962).

Infiltration of cold winter air can cool interior construction surfaces to a temperature at which they can reach the dew point of the interior air, resulting in condensation forming on these surfaces. Freezing of interior pipes, discomfort, and the transport of outside contaminants may occur as a result of uncontrolled air leakage into the building.

Exfiltration of moist interior air through the air barrier can result in condensation occurring within the glazing rabbet on colder surfaces. This additional water would have to be contended with and drained.

The air barrier location becomes complicated by the variety of planes that are providing this function. Sealants, gaskets, or other materials susceptible to water degradation should be located where they will only have limited contact or be accessible for periodic replacement.

5. A means of containing, collecting, and disposing of condensation should be developed within the framing profiles to contain condensate water that might accumulate on inner aluminum and glass surfaces.

Where moderate humidity levels are maintained and not exceeded, where adequate heat is provided, and where some air movement exists over the surfaces to break up the insulating air film, condensation should not be a problem. The use of add-on systems usually is aesthetically poor and leads to joints that may have to be sealed. The incorporation of condensate gutters is not a safeguard against water leakage, as one manufacturer often states. The drainage of a condensate collection system must not be back to the exterior, through the air barrier system, but should be from an evaporation trough at the sill or by mechanical drainage if a large amount of condensation is expected.

## DETAILS

The details presented do not represent any specific manufacturer's sloped aluminum and glass system. While conceptual for the purpose of this paper, the details are based on actual installations of modified manufacturers' systems available in the Alberta market. The details and text are based on a simple sloped glazed design where the head ties into a rain screen clad wall above, at the sill to a protected membrane roof and at the endwalls to a vertical curtainwall.

## GENERAL PROFILES

All of the details are based on two basic aluminum profiles—horizontal mullions (Figure 2) and vertical mullions (Figure 3). They are similar in design in that

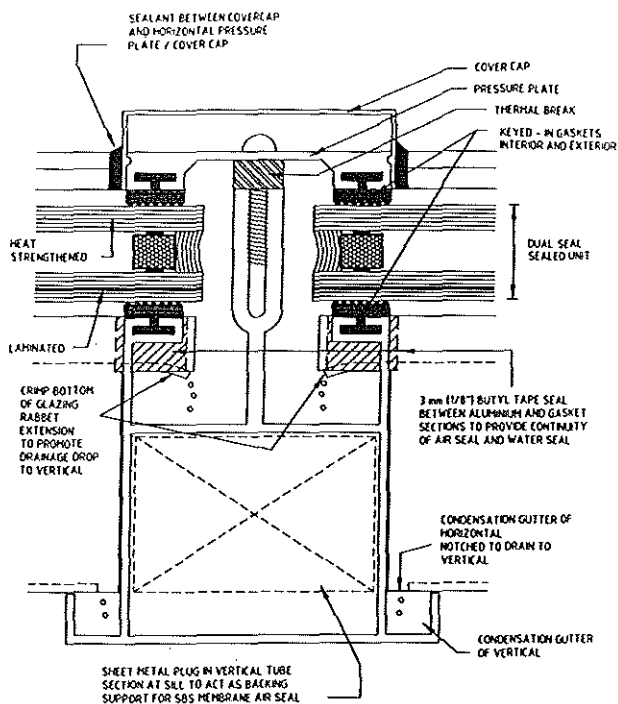

Figure 3 Vertical mullion.

the main tube section provides the structure to support the live and dead loads of the system. It may be economical to provide a miscellaneous metal frame under the aluminum framing to provide support when loads increase beyond the maximum allowable loading of the aluminum profile. Steel can be introduced within some aluminum profiles as well, but aesthetics and cost usually will govern which approach is taken.

The sealed units are installed from the exterior so that a minimum gap of 1/4-in. (6 mm) exists between the unit edge and the face of the screw spline. They are positioned by resting the sill edge of the unit on 80-durometer-hardness neoprene setting blocks positioned at quarter points of the length of the sill screw spline. The aluminum profile raises the edge support of the unit from the plane of the main tube face of the frame on a raised glazing leg. The raised leg of the gutter (glazing rabbet) has a keyed-in gasket to separate the glass unit from the frame. This glazing method allows the unit to be moved during placement to properly achieve the correct bite for the edge of the unit. The height of the raised leg of the glazing rabbet and gasket should be sufficient to elevate the joints between the aluminum and gasket and the edge of the sealed unit to prevent these points from ever sitting in water. A raised leg of 3/8-in. to 1/2-in. (10 mm to 13 mm) is of sufficient height as a rule of thumb for a horizontal member no greater than 6 ft, 0-in. (1.8 m) in length where the angle of slope of the system is 30 degrees or greater.

Water at the gasket could leak through the end joints of the gasket or between the gasket and glass to the interior. Water in contact with the edge of a sealed unit can cause some sealants used to manufacture the unit to swell or lose adhesion to the glass surface, resulting in seal failure. The polyvinyl butyral (PVB) plastic inner layer between the plies (layers of glass) of the inner lite of the sealed unit, when in contact with water, can discolor and affect the optical quality of the lite.

The units are held in place by an exterior applied pressure plate. This pressure plate should be thermally separated from the screw spline. This can be achieved by a polyvinyl chloride (PVC) or ethylene propylene diene monomer (EPDM) keyed-in profile that is secured to the screw spline and penetrated by the screw fasteners of the pressure plate.

The vertical pressure plate may or may not have a cover cap similar to that of a standard curtainwall. If it does have a cover cap, it should be designed to accept the fact that, from time to time, glaziers, window washers, and the maintenance staff may be walking on it. When they do, they may damage the profile and the clamping ability of the profile to the pressure plate. Such loss of contact can result in caps being caught by the wind and ripped from the system.

For the horizontal pressure plates, a low profile with no cover cap should be used to minimize the amount of water that is retained at the outside seal. The degree of

slope of the glazing and the height of the gasketed pressure plate will affect how much water and dust are retained at the horizontals. This is visible on barrel vault systems, where the top glazing is dirty and the lower lites are cleaner. Retention of water and dirt on the upper lites also may result in streaking of lower lites, where water eventually drains.

Some manufacturers promote the use of a silicone or semicapsless design for the horizontals. While this design approach does have some merit in minimizing the amount of water and dirt that is retained, it is not without a cost. The performance of silicones can be affected greatly or be a factor in the degradation of other elements used in the glazing system. Compatibility testing of the silicone with all contacting surface materials must be undertaken before and during construction and by maintenance staff in the future if work is to be undertaken. Preparation of component surfaces for priming, proper placement of the silicone, and tooling of the joint is essential to ensure acceptable long-term performance of this sealant. This exterior sealant weatherseal design may have to be installed in less than favorable weather conditions, whereas with a dry glazing and pressure-plate system, the limitations imposed by weather are not as critical. Only when the slope of the glazing system is nearly flat does the silicone weatherseal design seem to have a small benefit.

The dry gasket and pressure-plate approach prevents the units from being uplifted from the system, while at the same time providing an acceptable degree of watertightness. The drained design approach of the system acknowledges that whichever exterior seal approach is used it does not have to be 100% watertight for the life of the installation.

The main difference between the horizontal and vertical mullions profiles is in the design height of the raised leg of the glazing rabbet. Obviously, if the vertical mullion is to collect all the water draining from the horizontal mullions, it must be of sufficient height to provide that function. It also must be of sufficient height to protect the seals designed at the junction of the horizontal to vertical mullion from coming into contact with water, which could degrade them.

## HORIZONTAL TO VERTICAL MULLION INTERSECTION

The water that is collected and contained in the glazing rabbet must be directed back to the exterior, otherwise the water level would rise sufficiently to wet the interior seals and possibly enter through them to the interior. The horizontal mullion, therefore, drains into the vertical glazing rabbet (Figure 4), where it can be drained at the sill of the sloped glazing system to the exterior. If the two aluminum sections were to butt together, as in a standard curtainwall, the seal joint would constantly be

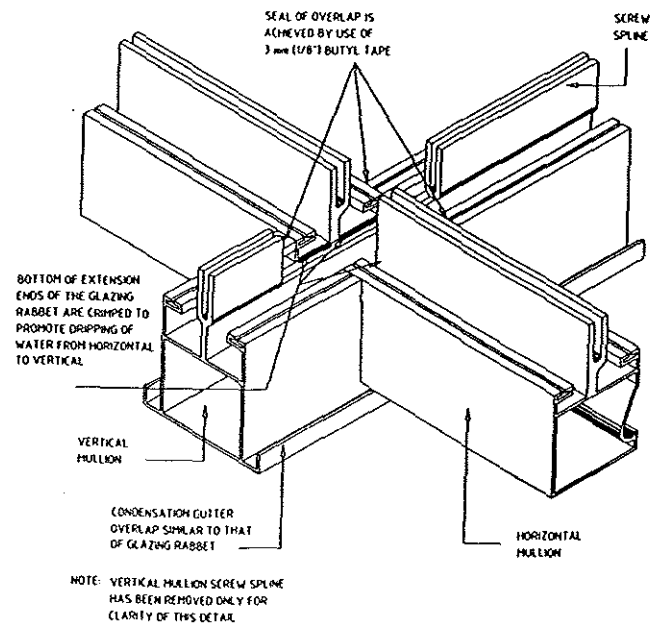

Figure 4 Horizontal-to-vertical junction.

in contact with water. If the horizontal glazing rabbet overlapped onto the tube face of the vertical glazing rabbet directly, the seal would still be exposed and the drainage of the vertical glazing rabbet would be restricted. The jointing of the horizontal to vertical mullions must therefore be overlapped and elevated.

As stated previously, the vertical glazing rabbet is greater in depth to ensure that it is not blocked by the overlapping extension of the horizontal glazing rabbet and at the same time to prevent water from coming into contact with the seals necessary between the aluminum sections to ensure a continuity to the air barrier. Water flowing down the vertical glazing rabbet, if of sufficient quantity, will form a series of waves similar to those seen on sloped sidewalks or roads. If these waves are slowed or interrupted, the resulting turbulence of the water can raise the water level in the gutter. Excessive caulking of the junction joint, debris within the system, and water dripping from the horizontals into the verticals can be disruptive to this wave pattern in the vertical glazing rabbet. To accommodate such situations, the overlap height should be at least 3/8-in. (10 mm). This depth may seem excessive to some manufacturers; in fact, most are not as deep. When investigating leakage at these joints, one often finds bits of construction debris, a fine dust powder, bits of vegetation, and insect bodies. If the system can self-clean, then the problems may never occur.

The extension overlap of the horizontal glazing rabbet should promote the dripping of water draining from the horizontal into the vertical. This can be accomplished by either cutting or crimping the lip edge of the

overlap. When there is only a small amount of water draining from the horizontal glazing rabbet, the surface tension of the water will cause the water to cling to the surfaces of the aluminum on either the underside of the horizontal glazing rabbet extension or on the upstand surfaces of the downslope screw spline and raised leg of the profile. This causes the water to flow on these surfaces and over the seal junction between the horizontal and vertical sections. If the surface tension can be broken by a drip at the termination of the horizontal, this contact with the critical air barrier and seal joint can be prevented and the potential for water entry can be eliminated (Figure 4).

The air barrier and water seal between the aluminum sections at this overlap often are a bead of sealant as recommended by the manufacturers. The authors' experience is that such an approach often is not acceptable. The glazier rarely prepares the surfaces and uses too much sealant, which can block the vertical glazing rabbet. The joint is anything but a "design joint," and should there be any movement of the aluminum sections after the sealant has set, the sealant probably will shear, leaving an open joint for water and air to pass through. If the sealing joint requires several applications of sealants between frame, gaskets, and glazing, other joint problems are introduced. For the available systems, the authors prefer the use of 1/8 in. (3 mm) thick by 1/2 in. (12 mm) wide butyl tape. In sloped glazing applications the authors have opened up after 15 years, the butyl tape is still pliable. This tape may have some self-sealing ability when it gets hot in the summer. One continuous strip of tape is used to seal from the top of the gasket on one side of the section to the top of the gasket on the underside of the section. It would be preferable to provide some design joint for the joints, but for now the tape approach is more forgiving. From investigations of problem sloped glazing projects, the most common failure at this junction is the reliance of the design on a sealant.

## SILL JUNCTION

A conflict between the designers, manufacturers, and installers of sloped glazed systems often is with regard to the sill junction. Designers want a minimal visual element. Manufacturers are reluctant to extend their systems beyond the perimeter plane of their exterior horizontal mullion sections into the gray area of trade responsibility between roofer, general contractor, and themselves. The result all too often is a lack of room and a variety of materials detailed, which forces the glazier to make an attempt at sealing this joint with caulking. The sill detail and the horizontal to vertical junction should be no different in how water is drained from one plane to another. The design should minimize the possibility of any water contact at the joint between alumi-

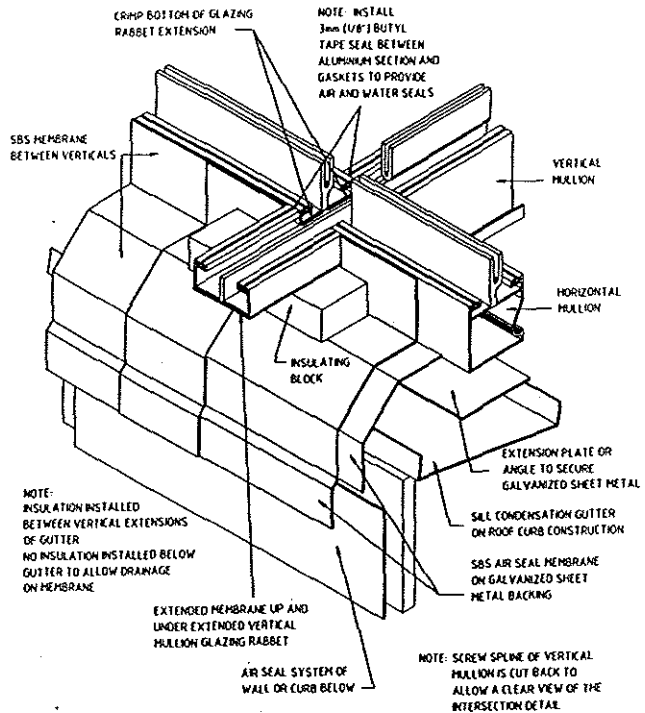

Figure 5 Sill junction.

num sections and the joint between these sections and the air barrier and water seal of the curb of the roof.

To do this, the vertical gutter of the glazing rabbet only is extended beyond the plane of the outer face of the horizontal tube mullion (Figures 2, 3, 5). The remainder of the vertical tube is cut back to the exterior plane of the horizontal tube so that the tube face can be used as the plane of air seal and waterproofing.

The air barrier and waterproofing seal of the protected membrane roof would be extended up the exterior vertical face of the roofing curb. From the curb to an extension angle or plate (depending on the manufacturer's horizontal profile), a 20-gauge (1.0-mm) galvanized sheet metal backing is used to provide structural support for a torch-applied reinforced SBS (styrene, butylene, styrene) membrane. The void created at the end of the vertical tube also must be plugged (Figure 3). The sheet metal is not overlapped at joints to minimize the buildup of elements. The metal surfaces are then primed with the membrane manufacturer's recommended primer and allowed to flash off.

Care must be taken when using a small detail torch to install the membranes. A pool of liquid SBS should be created before the roll of membrane and the membrane is rolled into the liquid, adhering the membrane to the surfaces. First, at the verticals, a width of membrane measuring 6 in. to 8 in. (150 mm to 200 mm) is extended up the surface from the curb to the sheet metal, to the plane of the horizontal, and to the underside of the glazing rab-

bet gutter extension, where it is cut to the width of the gutter extension and adhered to the underside of the gutter. The remainder is extended up the side of the raised legs of the gutter. It is critical that these cuts be accurate, otherwise air leakage will occur in the corner junctions. The remainder of the space between verticals is membraned from the curb to the plane of the horizontal with at least a 2-in. (50-mm) overlap of membrane joints.

A peel-and-stick membrane could be used. However, it is less workable in these tight confines, and, in hot conditions, the membrane may have a tendency to flow. The membrane top termination should be mechanically fastened to prevent such slippage. This detail protects the critical joints of the aluminum sections from having water on their surface, while at the same time extending a flexible system of materials from the roof curb to the aluminum sections, which is designed for water contact.

Rigid polystyrene, type IV, is used to provide the continuation of the thermal barrier from the roof up the exterior of the membrane to the face of the aluminum sections. A void of insulation is created at each vertical at the membrane plane so as not to restrict drainage on the membrane plane and, during colder weather, to allow sufficient heat to maintain water flow to the roof. At the underside of the glazing rabbet extension, a block of insulation is used to wedge the membrane against the underside of the extension to provide some resistance to slippage or sag of the membrane. Flashings are installed over the insulation to protect the insulation and provide an aesthetic appearance.

## HEAD JUNCTION

### Head

The air barrier and waterproofing functions are achieved by galvanized sheet metal and reinforced SBS membrane, sealing from the exterior glazing gasket key of the slope glazing system to the air seal of the rain screen wall above (Figures 2, 6). Here the vertical mullion tubes are extended for anchorage and also to provide for the sealing of the vertical glazing rabbets. A plug is needed for the vertical glazing rabbet profile, made from aluminum or neoprene, and laid into a bed of compatible butyl sealant. The plugs should be held back from the edge of the metal backer and membrane that overlaps it so that a drip can be created. This prevents the butyl seal from getting wet should water be entering the system from the above construction.

Water that enters through exterior joints or seals is contained on the membrane plane and drained to the glazing rabbet of the horizontal mullions and then from there into the vertical mullions. Insulation is installed on the exterior of the membrane. Flashings on the exterior are again designed to shed water but are not relied upon to be completely watertight. The flashings can be in-

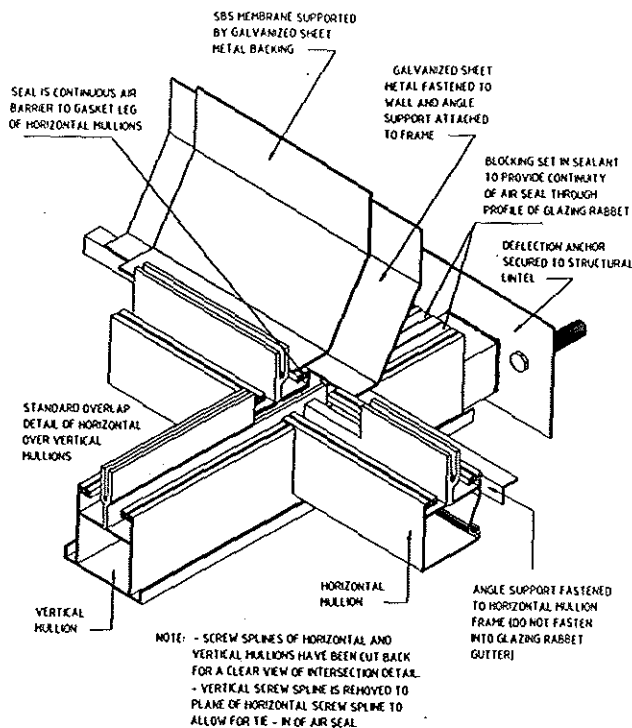

Figure 6 Head Junction.

stalled over the pressure plate and cover cap system, but this means that they have to be removed should glazing replacement be necessary. To install them under the pressure plates provides the mechanical fastening necessary and a finished look similar to that of the glazing itself. The only joint that would be necessary to seal would be the joint created between the pressure plate gaskets at the verticals. A plug or sealant can be used to minimize water entry and would have to be maintained.

## JAMB JUNCTION

The jamb detail (Figure 7) is similar in concept to that of the other two details in that all joints that could have water on their surfaces are shingled. The vertical end-wall would be designed as an exterior glazed and pressure-equalized curtainwall framing system. From this system, galvanized sheet metal is installed so that the exterior face of the sheet metal is flush with the tube face of the glazing rabbet and is brought flush to the top surface of the glazing gasket key of the raised leg. This can easily be accomplished by using aluminum angles fastened to the typical tube profiles of both systems, but special profiles also could be introduced. Fastening of these angles must not be made through into the glazing rabbet gutter of the sloped glazing system. The surface of the galvanized backer and the aluminum surfaces to which a membrane is to adhere are primed and a reinforced SBS membrane is installed in a shingle fashion from the tube face of curtainwall glazing rabbet to the

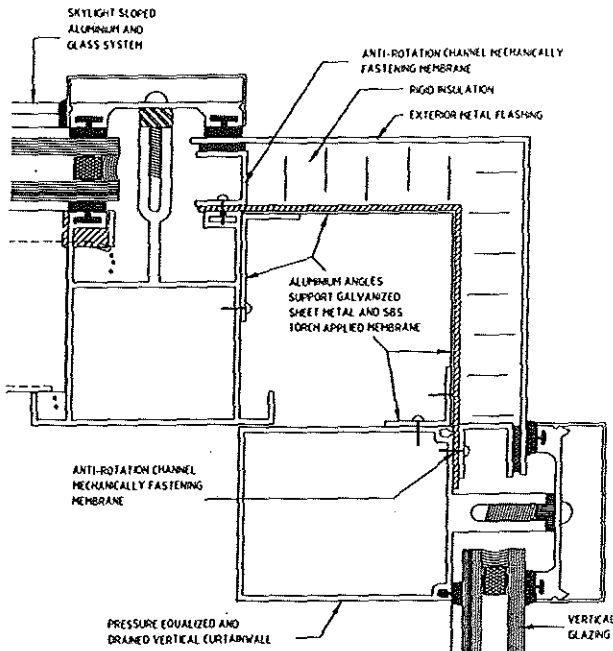

Figure 7 Jamb junction.

top face of the key profile raised leg of the sloped glazing framework. The membrane with the galvanized sheet metal backing now provides both the function of an air barrier and the plane of waterproofing. Water entering through any joint in the exterior cladding or seals is either drained into the glazing rabbet of either aluminum frame system or directed on the slope of the membrane back to the exterior at the sill. Anti-rotation channels are installed to provide support for the pressure plates and to mechanically retain the membrane.

Polystyrene type IV is installed on the exterior of the membrane and then covered with finished metal. All joints from the top of the sloped glazing are shingled and drained in a fashion where the vulnerable sealing products used to join the aluminum profiles and glazing to aluminum are not subjected to wetting.

## CONCLUSION

If these fundamental philosophies are followed in the variety of geometric designs for sloped glazing that are created in the minds of designers, one can see that the more complicated the design, the more complicated the details become. The standard sections available from most manufacturers have their limitations. If the project is exceptionally large, the cost of the variety of profiles necessary to achieve these details may be within budget. To reduce costs, it may be easier to simplify the design of the sloped glazing. The costs, however, do not start and end with the manufacturers of the aluminum extrusions. The costs start with the need for proper detailing by a

knowledgeable consultant and must continue through the shop drawing review, construction, and then maintenance of the system. Owners who feel they can reduce the importance and costs associated with each of these stages may be paying substantially more to fix the leakage problems later, especially if a lawyer becomes involved.

Ask any owner of a building what the main function of a roof is and he will state that it must be waterproof. The glass roof is no different. It should not leak. There is a great debate among contractors and designers as to how this can be achieved, but the owner of the building is the person forced to live with or pay for the problems should the approach taken be unsuccessful.

Sole reliance of an exterior-exposed seal as the only line of defense against water infiltration remains a fundamentally flawed concept. The continuous 100% perfect seal in construction does not exist. The alternative is to design a water deterrent at the joints of the exterior components that minimizes the retention of water at the joints and the possibility of water entry through the joints.

Within the interior profiles of the glazing rabbet of the aluminum extrusion, a gutter system is created that raises the glazing from a location where it could be sitting in water. The gutter system should contain and direct any water that passes through the inevitable imperfections of the exterior screen, from horizontal to vertical member in a raised and shingled design. The design of the overlap should prevent water from flowing over the joint air and water seal of the aluminum sections. The vertical glazing rabbet gutter must be designed to collect all the potential water entering it and direct it in a similar raised and overlapped design at the sill. The use and reliance on caulked, nondesigned joints that are subjected to water flowing over them leads to a limited performance life.

Total pressure equalization of this sloped glazed system may not occur in large or complex designs. Unlike vertical glazed walls, where individual units are compartmentalized, the drainage system necessary within sloped glazed systems interconnects these individual compartments through the glazing rabbet. The interior air seal of the system must still be continuous and may, depending on the detail, act as a water seal as well.

Control of water that infiltrates past the exterior seals is perhaps the most important attribute of a sloped glazing system, but the other functional requirements cannot be overlooked. The interweaving of air and water seals, overlapped and elevated aluminum profiled sections, and sealants and membranes is a tangled web, all of which must be designed, installed, inspected, and maintained to provide the function it was intended to perform—a roof of glass that does not leak.



## REFERENCES

- Brown, W.C., M.Z. Rousseau, and W.A. Dalglish. 1991. Field testing of pressure-equalized rain screen walls, exterior wall systems: Glass and concrete technology, design, and construction. ASTM STP 1034, B. Donaldson, ed., pp. 59-69. Philadelphia, Pa.: American Society for Testing and Materials.
- Dalglish, W.A., and W.R. Schriever. 1962. Wind pressures on buildings. Canadian Building Digest 34. Ottawa, Ontario: Division of Building Research, National Research Council of Canada.
- Garden, G.K. 1963. Rain penetration and its control. Canadian Building Digest 40.
- Handegord, G.O. 1979. A need for improved airtightness in buildings. Note 151. Ottawa, Ontario: Division of Building Research, National Research Council of Canada, Building Research.
- Quirouette, R.L. 1982. Building envelope design using metal and glass curtain wall systems. Note 37. Ottawa, Ontario: Division of Building Research, National Research Council of Canada, Building Practice.
- Quirouette, R.L. 1985. The difference between a vapour barrier and an air barrier. Note BPN 54. Ottawa, Ontario: Division of Building Research, National Research Council of Canada, Building Practice.
- Wilson, A.G. 1961. Air leakage in buildings. Canadian Building Digest 23. Ottawa, Ontario: Division of Building Research, National Research Council of Canada.